

Dry Saddlebag Instructions

Please read instructions carefully before installation. We recommend this product be installed by a qualified, and experienced technician. If you are unsure of any of the below directions and or your ability to correctly and securely install this product, please contact us or your local dealer for help. Below diagrams show typical installation, your vehicle may be different so please use diagrams as a guide. Make sure your vehicle is clean and free from dirt, road grime, etc. where the this product mounts. It is the drivers responsibility to make sure the product is mounted and secure before each use. **Always check for proper mounting and that straps are tight before each and every drive.**

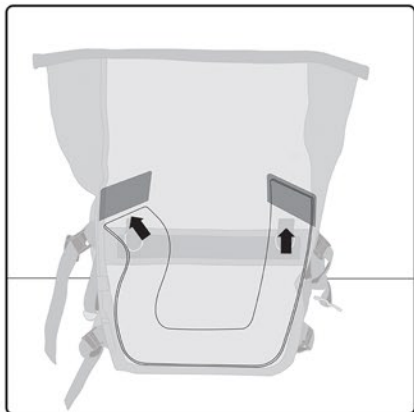

Take the included plastic stiffener and place into bag. Insert an end into one of 2 the pockets located on the top sides of the bag. Fold back the other side and insert into pocket on other side.



Pack contents in bag with heavier items at the bottom for better weight distribution and balance. Included are bag liners to pack your items for easy removal without having to inundate the saddlebags. Close the top opening while pushing out as much air as possible. Roll the now closed end down a minimum of 2 times.

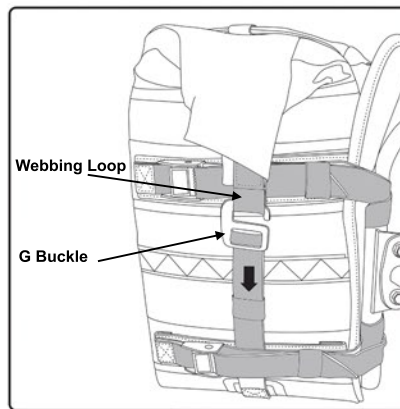

Webbing Loop
G Buckle

Once the top is rolled down tight, pass the side G buckles through the webbing loops on the opening on each side of the bag and pull snug. You can run these straps over (as shown on top) or under of the side mounting straps. (as shown on bottom)

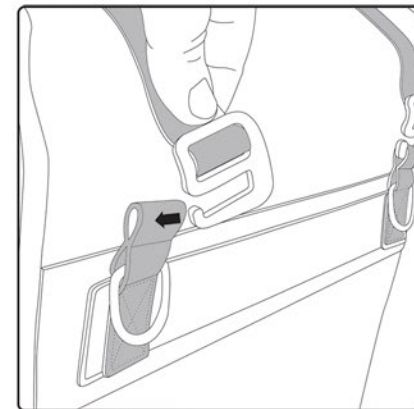

Then secure the top compression straps by again connecting the G buckles through the webbing loops on front of bag. Pull snug. These have intentionally been left long to attach some of our roll bags creating the ultimate waterproof luggage system.



Connect self fastening straps on each bag together as shown and position over, or if your bike allows, under the seat. Adjust straps to determine the height of the bags. Further adjustment may be necessary once bags are loaded to ensure they do not come into contact with your exhaust or moving bike part.

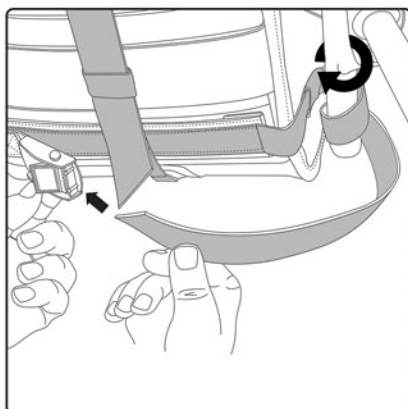

Take the strap connected to each cam buckle and wrap it around your rack. Its recommended to pass the strap around the rack 2 times as shown so the strap holds the rack tight and minimizes any slippage. **It is highly recommended to install these bags on a bike with saddlebag racks or supports.**

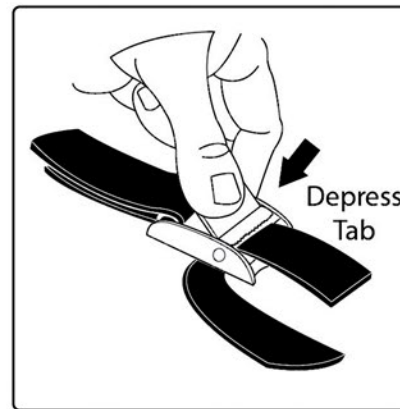

Depress Tab

Then feed the strap through the cam buckle and pull tight. Do not overtighten as the side straps mainly hold the bags against the rack only and when installed correctly, do not come under heavy load. Feed any loose strap into the provided elastic loops or trim to fit as needed



Warning

Read the installation instructions and make yourself familiar with the process of installing the Rigg Gear product(s) on your vehicle. It is your responsibility to install the product(s) correctly and securely as outlined in these instructions. Rigg Gear products must not be overloaded or over tightened. Failure to adhere to these warnings may result in, but not limited to, the product becoming detached, becoming tangled in moving parts of the vehicle, unstable vehicle dynamics, reduction in the ability to control the vehicle. The result(s) could lead to serious injury.

Always drive safely. Always wear a helmet and protective apparel.

3518-A Lake Center Dr Santa Ana, CA 92704
Tel (714)850-1811 Fax (714)850-1848
e-mail: info@RiggGear.com www.RiggGear.com

RIGG GEAR
ADVENTURE